

A Systematic Study of Zone Refining of Single Crystal Indium Antimonide

A. R. MURRAY, J. A. BALDREY

Texas Instruments Ltd, Bedford, UK

J. B. MULLIN, O. JONES

Ministry of Aviation, Royal Radar Establishment, Malvern, Worcs, UK

Received 6 October 1965

The experimental conditions have been determined whereby it is possible, in a closed system, to distil off volatile impurities from an ingot of InSb, and subsequently pass at least 10 to 15 zones through the ingot, whilst constantly maintaining a single crystal structure of a chosen crystallographic orientation. It has been found that preservation of singularity and control of dislocation density can be achieved by selection of: seed orientation and polarity; provision of a containing boat which is not wetted by InSb; careful purification of gas ambient; and the establishment of the correct conditions of temperature gradient at the crystal growing interface. A minimum concentration of $\sim 3 \times 10^{13}$ extrinsic electrons/cm³ was found in uniform specimens substantially uncompensated by volatile impurities. The work provides good evidence that this carrier concentration is not due to Te. The maximum electron mobility at 77° K that could be reproducibly obtained in uniform specimens was 7.5×10^5 cm²/V sec.

1. Introduction

The process of purifying InSb by horizontal zone refining has been extensively studied in recent years [1-8]. The present investigation was undertaken with a view to producing very high purity single crystal for use as a sub-mm wave photoconductive detector, the performance of which is sensitive to both the extrinsic electron concentration and electron mobility for material containing less than 10^{14} extrinsic electrons/cm³.

It is interesting to compare the experimental approach of various workers to the production of pure single crystal InSb. Vinogradova *et al* [1] claim to have produced an ingot containing material with an electron mobility in excess of 10^6 cm²/V sec at 77° K, from an experiment in which the ingot was zone refined in a sealed quartz tube under argon to a total of 66 passes. The final product was said to exhibit large single crystal regions, but no information is given regarding orientation and the detailed structure during processing. Parker *et al* [2] quote similar high mobilities on material zone

refined in hydrogen using sandblasted quartz boats, and subsequently regrown by the Czochralski technique to bring down the dislocation density. It was also found that an enhanced reduction in the extrinsic concentration occurred when the passes resulted in the formation of single crystals rather than a polycrystal. Parker considered that this effect was probably due to segregation at grain boundaries.

Hulme and Mullin [3] have described a method of preparing single crystal InSb having an extrinsic carrier concentration of 0.5 to 1×10^{14} carriers/cm³ and an electron mobility of 6.5×10^5 cm²/V sec at 77° K. Pre-evaporation to remove volatile acceptors and zone refining in the polycrystal state were followed by transfer to a Czochralski apparatus, where an additional pre-evaporation was performed before growing the charge as a single crystal. At the time this work was carried out, it was not possible to perform the zone passes on a single crystal ingot, due to the considerable difficulty of maintaining single crystal structure of controlled orientation. The latter feature was

regarded as particularly important in view of the variations in distribution coefficient of certain solute elements known to occur on specific areas of the growth front of an InSb crystal (facet effect) [3]. Similar effects are found in Ge [9] and Si [10]. Detailed mechanisms have been proposed by Trainor and Bartlett [11] and Holmes [12].

It is of importance to take account of this effect in optimising the purification process for InSb. The distribution of Te, in particular, is very susceptible to the specific growth condition employed. Harman [4] has shown that Te is usually found in InSb ingots, and there are grounds for considering that it may be responsible for the limiting donor distribution found by Hulme and Mullin [6] after extensive zone refining in polycrystalline form. In table I, the

TABLE I Comparison of segregation behaviour of "residual donor" and Te in InSb

Orientation	Distribution coefficient $K_{eff} \approx K^*$	
	"Residual donor"	Te
Single crystal on (111) facet	3-7	4.2
Single crystal off (111) facet	~ 0.5	0.47
Polycrystalline	~ 0.9	0.9

known segregation behaviour of Te in InSb is compared with that of the "residual donor". It is felt that, while the proposal of Parker *et al* [2] that grain boundary effects limit donor segregation in zone refining of polycrystals may be valid, it is very likely that facet effect non-uniformities arising from a randomised series of orientations may be the dominant mechanism.

The present study was undertaken as an extension of the work of Hulme and Mullin [6], using a seed crystal to maintain singularity of the ingot during the zone passes and thereby providing optimum segregation conditions for impurities (in particular, Te). This approach differs from that of Vinogradova [1] and Parker [2] and their co-workers, inasmuch as a pre-evaporation to lower the net concentration of acceptors was used, and provision of a seed crystal gives direct control over the orientation, as opposed to relying on the self-seeding properties of the ingot. A further advantage of this latter feature is that it avoids production of

$\langle 111 \rangle$ or $\langle \bar{1}\bar{1}\bar{1} \rangle$ type orientations which give rise to anisotropic segregation on the growth front.

The account which follows describes the development of a reliable crystal growing technique for the production of high purity material. The results obtained are discussed in terms of twinning, dislocations, and solute segregation; together with some speculations regarding the nature of the "residual donor".

2. The Basic Apparatus and Measurement Techniques

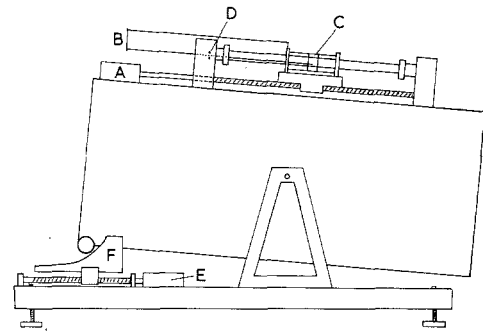

Figure 1 Zone refining apparatus: (A) Furnace drive motor; (B) Linkage which permits Chromel-Alumel thermocouple (located at zone centre) to be moved at the velocity of the furnace; (C) Section of furnace windings which form the liquid zone; (D) O-ring seal for thermocouple sheath; (E) Tilt-drive; (F) Tilt cam.

The zone refiner is shown schematically in fig. 1. A quartz work tube 30 mm internal diameter was supported at both ends by water-cooled duralumin posts, one being drilled to allow insertion of a travelling thermocouple with hot junction located always at the centre of the refining zone, the other giving access to ambient gas or a high vacuum system. The travelling furnace element consisted of a slotted quartz muffle wound with nichrome V, tapped off at intervals with the sections individually controlled. Provision was thus made for initial pre-baking of the whole ingot and traverse of a restricted zone formed by the centre windings only. The temperature gradient in the refining zone could be modified by feeding power to the adjacent furnace sections. A magnetic amplifier servo-system was fed from the thermocouple signal and was found capable of holding temperature to within about 0.2° C from a pre-set value. The frame was pivoted on a central spindle, and a motor-driven cam was used to

vary the tilt angle during the zone pass, in order to avoid excessive transportation of material in the direction of traverse.

All electrical measurements were made on rectangular specimens $12 \times 3 \times 2$ mm cut from the ingot with a wire. The final finish was achieved by: lapping, with 600 grade carborundum powder; degreasing; washing; and drying. Hall coefficient measurements were made at 77° K at three points sited at 3 mm intervals along the specimen length, using spring-loaded tungsten contacts. Conductivity measurements were made both between adjacent and alternate probes. The Hall field was 3.8 k oersted. It was considered very important to measure specimen uniformity. Excessively large values of mobility, for example, have been recorded when measuring non-uniform specimens. The mean deviation of measurements on specimens lay in the range ± 3 to $\pm 10\%$. Specimens showing less uniformity were invariably from the vicinity of a p/n junction or an edge (111) facet and could be disregarded.

Extrinsic carrier concentrations were calculated as $(6.25 \times 10^{18})/R$ carriers/cm³, where R = Hall coefficient. Carrier mobility was calculated as $R\sigma$, where σ = conductivity.

3. Factors Affecting Single Crystal Growth and Perfection

3.1. Container Materials

It was decided to make a detailed study of possible container materials, since previous experience had shown that correct selection of same has a considerable bearing on the problem of maintaining single crystal growth during zone refining.

The preferred material in most laboratories appears to be fused quartz. It was found that zone refining in clean, untreated, quartz boats gave rise to wetting, as shown by a sharp edge on the ingot between the free surface and that in contact with the boat (see cross-section in fig. 2(ii)). Sticking between InSb and smooth quartz undoubtedly occurs at temperatures near the melting point and is relieved as the ingot cools. Crystals aligned on [111]* could be grown successfully, but the resulting dislocation density was very high, due to the strain imposed by differential contraction of SiO₂ and InSb when cooling takes place with the materials in intimate contact. The use of a [111] axis was

found to be undesirable for other reasons too (see section 3.2.2.). It was found impossible to maintain single crystal growth on other axes, due to the ease of nucleation of stray crystallites. Sooted quartz, prepared by the application of a benzene or paraffin flame, gave rise to non-wetting, and hence strain-free conditions, but the incidence of twinning was still high. A further disadvantage of loose coatings of this type is the possibility of accidental dislodgement giving localised wetting and scum on the ingot surface. Although Liang [5] has questioned the use of carbon on the ground that it may be an electrically active impurity, the present results would not appear to bear this out (see section on purification).

The wetting of some potential boat materials was studied by melting small samples of InSb on a flat plate of the test material in an ambient of pure argon. An estimate of suitability was made on the basis of contact angle of the droplet and examination of the contact surface after freezing. Boron nitride gave a high contact angle and the sample adhered strongly to the test plate on cooling. Abraded quartz and various grades of fused alumina gave somewhat lower contact angles and no adhesion was found, although the contact surfaces of the specimens were generally roughened. The lowest contact angles were given by clean silicon nitride and abraded quartz with a rubbed-in coating of carbon. Molten droplets on these materials were highly mobile and exhibited bright contact surfaces with no sticking. It was concluded that they were the most likely alternatives.

Attempts were made to grow single crystal ingots in quartz boats with sandblasted interiors in the manner of Parker *et al* [2], but results were generally the same as for untreated quartz, and it was not found possible to grow single crystals on orientations other than [111]. The crystal orientations which Parker specifically reported as examples of single crystal growth were [111] and the twinning derivative [115]. Wetting of the container would explain the high dislocation content of these ingots.

At the time that this work was carried out, silicon nitride was not available as a crucible of the required length and geometry, so effort was directed towards using the carbon-coated abraded quartz. Excellent results were obtained. It was later found that good non-wetting condi-

*We use the convention wherein the face "terminating in Sb atoms" is labelled (111) and that "terminating in In atoms" ($\bar{1}\bar{1}\bar{1}$) [3].

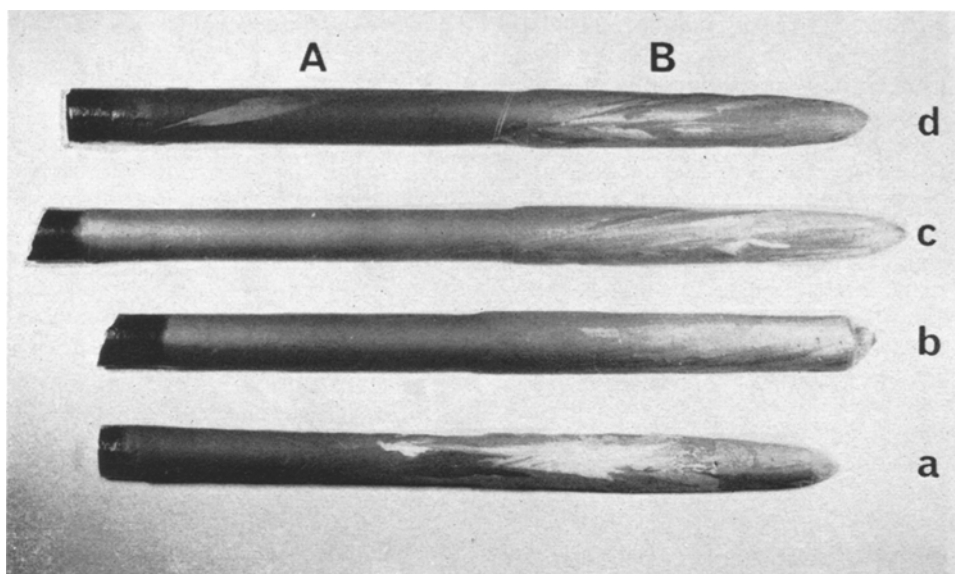

Figure 2 (i) Effect of container materials on crystalline perfection of InSb ingots. Seeds at end A of each ingot.

A Sandblasted quartz	B Smooth quartz	
+ pyrolytic carbon deposit	+ pyrolytic carbon deposit	d
+ rubbed in colloidal silica	clean	c
+ rubbed in carbon	clean	b
clean	clean	a

Single crystal growth occurred only on Ab and Ac surfaces. The increase in ingot width is an indication of wetting.

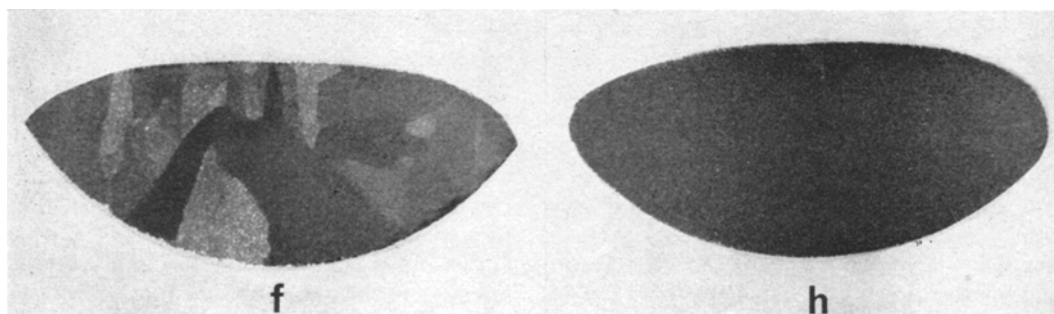

Figure 2 (ii) Wetting of container materials. Ingot cross-sections indicate: f a wetting condition (section from Ba in fig. 2(i)); h a good non-wetting condition (section from Ac in fig. 2(i)).

tions were also obtained if colloidal silica* was substituted for carbon. The contrasting effects of various containing boat preparations on the crystalline perfection and wetting behaviour of ingots grown from [331] seeds are shown in figs. 2(i) and 2(ii). The structure in the ingots was revealed by first sandblasting them and then etching them. The basic effects of the boat preparations are reproducible. The experiments clearly indicate that single crystal growth is dependent on the container material. The most satisfactory treatments involved the use of colloidal silica or carbon on abraded quartz.

3.1.1. Detailed Method for Preparation of the Containing Boat

Semicircular-sectioned quartz boats 11 mm in radius and 33 cm in length were used. The first step in their preparation was to sandblast the interior uniformly with 27 μm alumina powder. After rinsing and degreasing, the boat was covered with 48% HF for 1 min in order to remove any traces of impurity. It was then rinsed in high purity water and dried in air before applying the carbon.

In earlier experiments, a soot coating was applied from a purified paraffin wax candle and then gently rubbed into the sandblasted surface using a soft paper tissue to give a uniform, matt finish. It was later found that the incidence of twinning was reduced if other sources of carbon were used. Consistently good results have been obtained from carbon prepared by thermal decomposition of pure toluene at 800°C. The product was usually re-baked under vacuum to eliminate tarry matter and moisture, and stored in a vacuum desiccator pending application to the boat surface.

Colloidal silica was applied by spraying from an acetone suspension or by stroking into the surface using soft tissue soaked in acetone or alcohol. Since finely divided carbon or silica will readily absorb moisture and oxygen from the atmosphere, it was found essential to vacuum bake the coated boats immediately prior to use. This also serves to ensure the elimination of fluorine from the HF treatment. (The possible significance of fluorine as an acceptor contaminant is discussed later in the paper.)

Small single crystal ingots of InSb have more recently been prepared using vitreous carbon†

boats with a suitably roughened interior surface. No intermediate coating was required.

3.2. Other Factors Affecting Twinning

With the establishment of a non-wetting condition between ingot and container, the probability of twinning is a function of certain other factors, which will now be examined in detail.

3.2.1. Growth Ambient

Single crystals have been grown in atmospheres of hydrogen, helium, argon, and high vacuum. For most of the present work, hydrogen was used. It was purified by passing through a palladium diffusion furnace. Very clean melts were obtained, and any twinning was usually attributable to other factors. No exceptional difficulties were found in making single crystal zone passes in vacuum, although antimony losses tended to give constitutional supercooling, and it was necessary to heat the entire ingot to avoid condensation of antimony on the surface.

Twinning was more frequently encountered when using rare gas ambients, and this is thought to arise from traces of oxygen or water vapour. Single crystals can only be produced when rigorous measures are taken to exclude these impurities from the gas stream and eliminate air leaks from the system. A calcium trap operating at 500°C and drying train (molecular sieve or $\text{Mg}(\text{ClO}_4)_2$) has usually been found satisfactory. The exact manner in which traces of oxygen initiate twinning is not clearly understood, but our experience is that a similar effect is found in the growth of Ge crystals.

3.2.2. Seed Orientation and Polarity

The subject of twinning in InSb has been discussed in some detail by Haasen [13], Mullin [14], and Hulme and Mullin [3]. The important aspects may be summarised in the following way.

When a growth direction of the type [111] or $[\bar{1}\bar{1}\bar{1}]$ is employed, the growth front is likely to be composed of three distinct regions: (a) a central or "principal" facet of the type (111) or $(\bar{1}\bar{1}\bar{1})$; (b) a stepped region surrounding the principal facet; and (c) edge facets of the type $(\bar{1}\bar{1}\bar{1})$ or (111). The properties of these regions have been elucidated by making use of auto-

*Colloidal silica is a product of British Drug Houses, Poole, Dorset. Its use was suggested by Mr A. Trainor of the Mullard Research Laboratories.

†Obtained from Plessey (UK) Ltd.

radiographs of radiotellurium-doped crystal sections. These have shown that the principal and edge facets are regions where the incorporation of Te is considerably enhanced at the expense of the stepped region. Also that $\{111\}$ edge and principal facets are large compared with $\{\bar{1}\bar{1}\bar{1}\}$ formed under the same growth conditions. Experience with pulled crystals has shown that twinning is very frequently encountered when the edge facets are $\{111\}$, i.e. Sb-terminating, and that the twinning is initiated on these facets. Conversely, twinning from $\{\bar{1}\bar{1}\bar{1}\}$ facets is comparatively rare whatever the growth direction employed. Edge facet twinning is much more likely than a twin on the principal facet, probably due to the fact that the latter is only in contact with supercooled melt, whereas the edge facets can also be exposed to ambient or, in the case of horizontal growth, the container. During $[111]$ and $[\bar{1}\bar{1}\bar{1}]$ growth, the three edge facets which are produced are opposite in character to the principal facet, and it follows that growth in the $[\bar{1}\bar{1}\bar{1}]$ direction produces three large $\{111\}$ edge facets which are prone to twinning. The situation is reversed if growth takes place in the $[111]$ direction. The $\langle 111 \rangle$ and $\langle \bar{1}\bar{1}\bar{1} \rangle$ directions are therefore unique in InSb, since in one case the maximum possible number of twin-prone edge facets will occur, but in the other case they will normally be absent altogether. This explains why $[111]$ oriented single crystals may be grown or may occur spontaneously in untreated quartz boats. The vulnerability of Sb-terminating edge facets has also been pointed out by Mueller and Jacobson [15].

It can be seen that if preservation of single crystal structure were the only consideration, the optimum growth direction would be $[111]$, and it is unfortunate that this direction gives rise to non-uniform impurity distributions. Consideration was given to employing this direction with a concave growth front, to suppress supercooling and hence principal facet formation. However, it was found that some radial anisotropy of distribution was present even under these conditions, and it was decided to attempt the use of some other axis, bearing in mind that at least one Sb-terminating (111) facet would have to be tolerated.

The first attempts were made using $[100]$ and $[311]$ oriented seeds, a somewhat arbitrary choice arising from their availability from pulling experiments. The seeds were ground to fit the boats and etched to a bright surface

before use. Considerable twinning was encountered initially, but with refinements to the boat preparation technique it was found possible to grow $[221]$, i.e. the twinned derivative of $[100]$, with considerable reliability. $[331]$ gave similar results, and these directions were used exclusively in the purification work to be described.

Single crystals have also been produced on $[211]$, although a tendency for the generation of lamellar twins was found. Experience with vertical pulling suggests that similar trouble would be encountered with $[110]$. Later attempts to prolong growth on $[311]$ and $[100]$ were unsuccessful for reasons which are not yet clear.

It was found that when good growth conditions were established, the effect of seed polarity on frequency of twinning was only significantly different for $[111]$ and $[\bar{1}\bar{1}\bar{1}]$ directions. For good crystal growth however, polarity must be taken into account, since it affects the dislocation content of the crystal.

3.2.3. Disposition of the Ingot in the Containing Boat

The experimental evidence clearly indicates that twins are more likely to form on $\{111\}$ facets in the region of the solid-container-ambient boundary than facets elsewhere on the growth front periphery. The reason for this is not understood in detail, but it may be associated not only with the supercooling due to the facet, but also with the supercooling associated with the rapid change of peripheral curvature of the liquid adjacent to the container wall. Fig. 3 is an

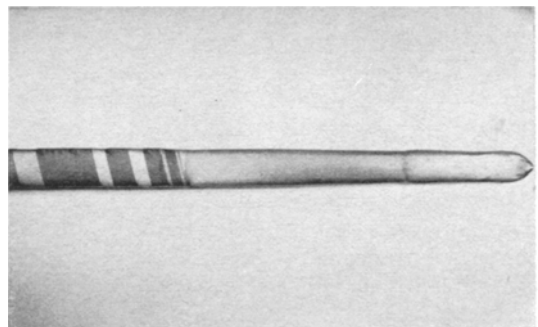

Figure 3 Prevention of twinning from edge facets. The proximity of the facet to the solid-container-ambient boundary has resulted in twin planes in the first half of the crystal. Single crystal developed when the second half of the crystal was regrown with the ingot rotated in the boat to keep the facet away from this boundary.

example of a crystal in which the (111) facet, which formed at the solid-container-ambient boundary, has resulted in a series of parallel twin planes in the first half of the crystal. Finely-spaced twins on alternate orientations can also be seen. The second half of the crystal demonstrates that the twins could be avoided by rotating the ingot in the boat so that on re-growth the facet would no longer be adjacent to the solid-container-ambient boundary. This effect is reproducible.

3.3. Maintenance of Single Crystal Growth through many Zone Passes

Using the preparation techniques described, it was found possible to perform one setting-up operation and thereafter preserve singularity through a series of zone refining passes. In the course of the purification studies, it became evident that in order to produce high quality material it would be necessary to pre-evaporate the charge in the presence of the seed, introduce hydrogen, and proceed immediately to zone refining without any intermediate handling.

TABLE II Statistics relating to preservation of single crystal structure during multiple zone pass experiments, using carbon or silica coatings on the containing boats.

	Carbon	Silica
Total number of complete experiments	11	9
Experiments with all zone passes in single crystal form	4	5
Total number of single crystal zone passes	72	86
Total number of passes with one or more growth twins	12	9
Total number of polycrystal zone passes	9	5

Table II shows the incidence of growth twinning and polycrystallinity encountered in routine experiments of this type. Colloidal silica boat coatings appear to be slightly more reliable than carbon, probably because they are less susceptible to detachment.

3.4. Control of Dislocation Density

Control over dislocation density is not technically difficult and dislocation free ingots can be produced by the application of the principles outlined by Cressel and Powell [16] for Ge

ingots. Good seeding-on and a completely non-wetted containing boat are essential. If portions of the boat coating become detached, wetting will occur and give rise to high dislocation densities if not polycrystallinity. The ideal surface contour of the growing crystal is planar or very slightly concave. Moderate convexity gives rise to a slip and dislocation distribution similar to those seen in Ge. Quantitatively however, if the same curvature of the growth surface is used, fewer dislocations appear to be introduced into InSb crystals than either Ge or Si crystals. The growth temperature and temperature gradients are lower in the case of InSb than in the case of Ge and Si. Hence, it is probable that InSb crystals are subjected to a longer annealing period in the plastic region. If the growth surface of the solid was made markedly convex, InSb crystals developed an irregular interface which quickly degenerated into polycrystallinity.

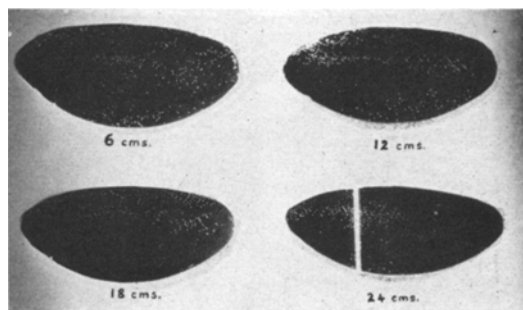

Figure 4 Dislocation etch-pit distribution in a [331] crystal showing propagation of dislocations even through twin boundaries.

The choice of growth direction is also important in growing dislocation-free material [17]. It is desirable to avoid growth directions near $\langle 110 \rangle$, since in these directions the experimental evidence shows that dislocations can readily be propagated throughout ingots. Fig. 4 is an example of dislocation propagation from a [331] seed, i.e. $\sim 13^\circ$ off the [110]. The similarity in the dislocation distribution is evident in the first three specimens taken at various distances (cm) along the ingot. The final specimen is interesting in that the dislocation grouping is not interrupted by the two twin planes. This may be an indication of screw character. The dislocation density can be reduced in ingots by growing them in directions away from the $\langle 110 \rangle$. Dislocation-free ingots have been

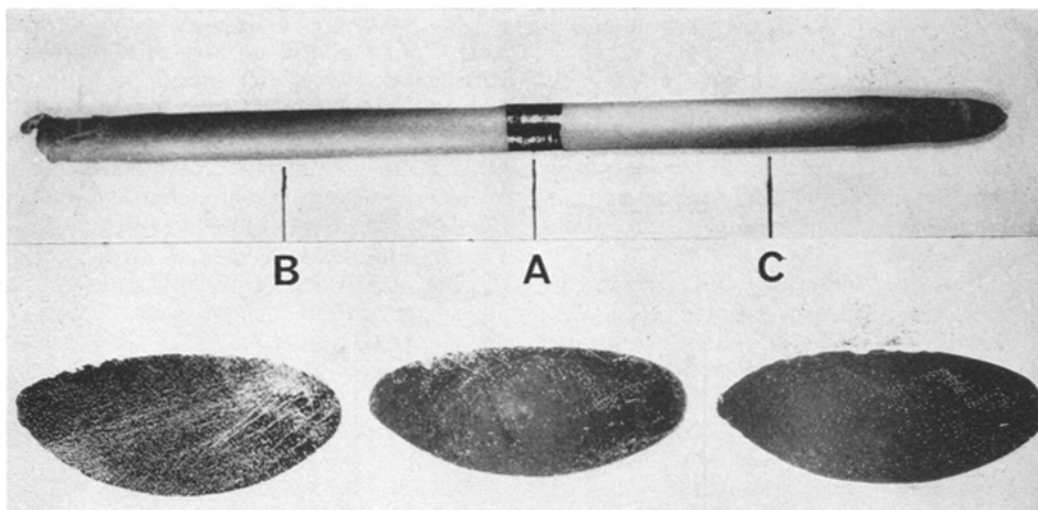

Figure 5 Effect of seed polarity on the density of dislocation etch pits. The etch pit density in an ingot grown from opposed ends of a seed shows a dramatic increase in the $[3\bar{3}1]$ direction, B, over that in the seed A, and that in the $[331]$ direction, C.

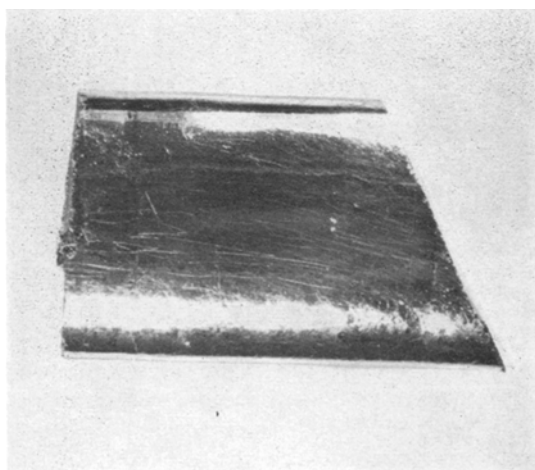

Figure 6 Lineage produced by growth in the $[\bar{3}\bar{3}\bar{1}]$ direction.

grown in the $[111]$, $[211]$, and $[221]$ directions. As noted above, wrong polarity was not observed to have a drastic effect on the rate of twinning for the orientations used. However, accidental reversals of the seed during routine zone refining experiments have led to the discovery that wrong polarity gives rise to excessive generation of dislocations. This was subsequently verified by deliberate experiment. Fig. 5 illustrates the result of growing from opposed ends of a seed ($[331]$ and $[\bar{3}\bar{3}\bar{1}]$); the zone length, interface contour, and temperature gradient being reproduced as exactly as possible for each extension.

The distribution of dislocations, as revealed by etching with CP4, clearly shows that growth in the $[331]$ direction does not result in a greater dislocation density than in the seed, whereas growth in the $[\bar{3}\bar{3}\bar{1}]$ direction, or "wrong" direction, results in a considerably increased dislocation density. Prolonged growth in the direction of "wrong" polarity can give lineage and eventual polycrystallinity. On a clean ingot surface, the lineage is manifested as faint irregular lines roughly parallel to the growth axis (fig. 6).

4. Factors Affecting the Purity

4.1. Preparation and Compounding of the Elements

In and Sb were obtained from several sources, but most of the work was carried out using "69" grade Sb and "59" grade In supplied by the Consolidated Mining and Smelting Co of Canada. Satisfactory results were also obtained using A1 grade In from Johnson Matthey and Co, and high purity Sb from Associated Lead Manufacturers Ltd.

Zone refining of the Sb produced no significant improvement of the high grade starting material used. Untreated quartz boats were found adequate for this purpose.

Radiotracer determinations carried out using ^{69}Zn showed that Zn was efficiently removed from an In melt under vacuum. All In was therefore treated in this way before use. Since

In readily sticks to quartz, it was found convenient to carry out the vacuum bake in a quartz boat, and then form the compound by adding Sb in slight excess over the stoichiometric ratio. Fusion followed by a slow normal freeze then allowed extraction of the InSb ingot with an Sb excess at the tail. Alternatively, In can be melted in carbon or carbon-coated boats without adhesion.

Possible surface impurities were removed by etching Sb in pure concentrated HCl with H_2O_2 addition, and In in pure concentrated HNO_3 , followed in each case by thorough rinsing in deionised water. This treatment was not effective in preventing the formation of an extraneous substance on the surface of the compounded ingot. This is thought to be carbon, derived mainly from the Sb [18]. When processing in bulk, this can be separated by bottom pouring [2, 5]. Alternatively, it can be removed by sandblasting. In any event, it is essential to commence processing of the compounded material with a completely scum-free surface, otherwise the effectiveness of the pre-evaporation will be considerably reduced, and singularity at the zone refining stage may be hazarded. For this reason, a final etch treatment of the ingots was carried out prior to processing. When the zone refining method had been established attempts were made to process the material exactly as removed from the suppliers' packages, i.e. without any etch treatments whatsoever. A somewhat inferior end product in terms of both purity and structure invariably resulted.

4.2. Pre-evaporation and Zone Refining

After compounding and surface cleaning, ingots were held molten in a vacuum of approximately 10^{-5} mm Hg for a period of 4 h, to distil off volatile acceptor elements. A calculated excess of Sb (~ 2 g Sb per 100 g InSb) was added during compounding. After the vacuum treatment, transfer was made to a second apparatus where single crystal zone refining was carried out using a suitably oriented seed and a container prepared as described earlier. Except where noted, the zone refining procedure consisted of single passes carried out at 3 cm/h. The zone length was normally 2.5 cm, i.e. ingot length to zone length ratio 12:1. Initial results were disappointing due to persistent acceptor contamination which gave the ultimate carrier distribution shown in fig. 7. Similar initial acceptor distributions were found by Vinogradova *et al*

[1] and Parker *et al* [2] in their ingots which were zone refined without pre-evaporation. Removal of this acceptor was considered essential, since meaningful results for the expected residual donor segregation could only be obtained in the absence of compensation. Two sources of acceptor contamination were eventually found. These were the use of separate evaporation and zone refining apparatuses and the use of HF in etch treatments of the ingot and quartz ware.

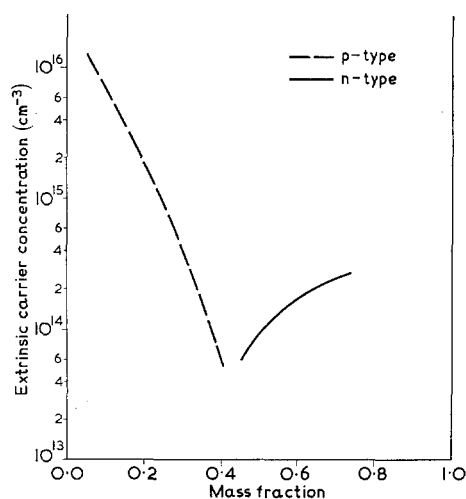

Figure 7 Distribution of carriers in an InSb ingot after pre-evaporation, "etch-cleaning" and 10 single crystal zone passes.

To overcome these difficulties "closed system" processing was adopted: the pre-evaporation and single crystal zone refining were carried out in the same apparatus, which was not opened to the atmosphere between the two stages. Contamination attendant on even the most careful handling of InSb is well established as reported by Hulme and Mullin [3], who found a second pre-evaporation necessary in order to grow an n-type Czochralski crystal from zone-refined n-type ingots having 1×10^{14} extrinsic carriers/cm³. An attempt to overcome this problem by combining zone refining and Czochralski growth in a single apparatus has also been reported [8]. The ease of introduction of contaminating acceptors is illustrated by the carrier distributions in fig. 8, which refer to an experiment in which two ingots from a common stock were successively pre-evaporated and zone refined by the closed system method. The zone pass sequence was interrupted after 3 zones in one

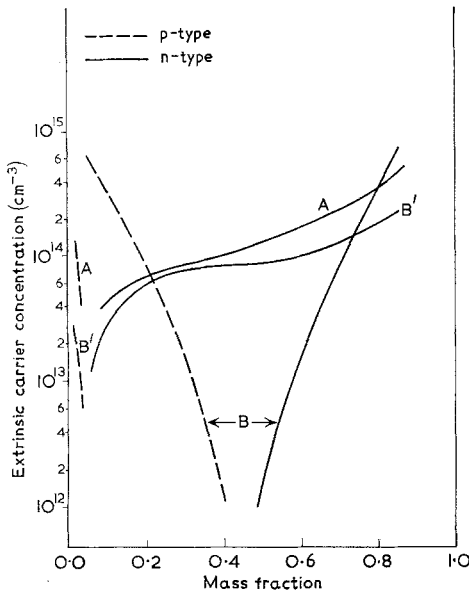

Figure 8 Acceptor contamination by handling. Curve A shows carrier distribution in a control ingot which was given "closed system" processing using pre-evaporation and 10 zone passes. Curve B shows the effect of temporarily removing an ingot from the system, using the same general technique (see text). Curve B' shows distribution obtained after subjecting the contaminated ingot to a pre-evaporation followed by 10 zone passes.

case to remove the ingot and wipe a trace of carbon off the surface with a clean tissue. This was followed by immediate reloading and a further 7 zone passes. Although the nature of the contamination is consistent with the introduction of Zn, analysis did not reveal the presence of this element in samples of the tissue and the precise mode of introduction is not known.

The use of HF in etch compositions was discontinued after comparative experiments had confirmed that it was introducing acceptors into the material. It is suspected that fluorine may be an interstitial acceptor [3, 19]. The following method was finally adopted for etching of InSb.

The ingot is placed in a polythene trough and supported therein on small quartz runners. HNO₃ with a small admixture of HCl is then added in sufficient quantity to cover the ingot surface, and reaction is brought about by addition of a further quantity of HCl. When it is required to stop the reaction, excess HCl is poured into one end of the trough, so that the reaction mixture is forced out at the other end.

The HCl is in turn flushed away with deionised water, and the ingot then transferred to another vessel for more prolonged rinsing.

Quartz components can be cleaned before zone refining by successive immersions in HNO₃/HCl, HCl and deionised water. Firing at 900° C in a tube furnace is a useful final step to ensure total removal of traces of the reagents.

Results achieved by zone refining InSb as a single crystal as opposed to a polycrystal are compared in fig. 9, where the area between the dotted lines shows the residual donor spread for six successive pre-evaporated zone-refined polycrystals, while the area between the solid lines represents the spread obtained with 14 ingots employing the "closed system" single crystal technique. About 10 zone passes were used in all cases. A curve representing the mobility distribution in the single crystal ingots is also shown; it was obtained by plotting the mean value of the mobility measurements at equivalent positions in each ingot. It should be noted that the lowest carrier concentrations correspond with the lowest mobilities, indicating that compensation was still present. The cross-sectional uniformity of the single crystal ingots was very good - typical measurements of 7 specimens from a cross-section yielded Hall coefficient values which showed a standard deviation of $\pm 5\%$.

Certain precautions must be observed when using the closed system method. The seed must be in position in the containing boat during the

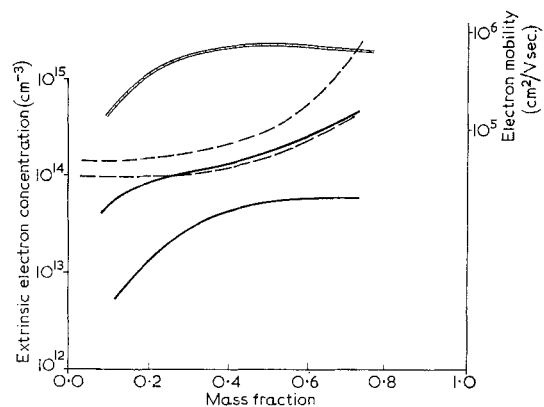

Figure 9 Comparison of the effectiveness of polycrystal versus single crystal zone refining. Area between dotted lines shows residual donor spread for 6 successive pre-evaporated zone-refined polycrystalline ingots. Area between solid lines shows corresponding spread for 14 ingots zone refined as single crystals using the closed system technique. The hatched curve shows the averaged mobility values for the single crystals.

pre-evaporation, and must be maintained at a temperature sufficient to prevent surface deposition of the volatile matter discharged from the melt. Also, when zone refining, it is important not to allow the hot furnace element to overrun the condensate which forms on the inner wall of the work tube, otherwise reverse transport of impurities may take place.

4.3. Reduction of Acceptor Content by Further Vacuum Treatment

Additional experiments have been performed to see if any improvement can be made to the general distribution shown in fig. 9, particularly with respect to mobilities, for mobilities in excess of 7.5×10^5 cm²/V sec are rarely observed. (Since the usual growth ambient is

hydrogen, care must be exercised in quoting figures for both mobility and excess donor concentration, as both are subject to changes with time due to ageing* [20]. Figures quoted in the present work refer to as-grown measurements.) It is normally found that after zone refining the ingot is p-type at 77° K in the region adjacent to the seed, the proportion being 5 to 10% of the zoned length. This is presumably due to a residuum of Zn which survives the pre-evaporation. Alternatively, the contamination may be continuously derived from the growth environment, but this is considered somewhat unlikely in view of the fact that all the surrounding quartz ware receives the vacuum baking treatment and a static ambient is used.

Attempts were made to eliminate Zn from the

TABLE III Evaporation of ⁶⁹Zn from In and InSb melts

Ingot no.	⁶⁹ Zn concentration (ppm by weight)	Bake time (min)	Ambient	% ⁶⁹ Zn loss	Remarks
1(1)	1.07	90	High vacuum	96.2	Surface oxidised due to system leak. Set up for a second vacuum bake still in oxidised state.
1(2)	0.04	150	High vacuum	Nil	Some Sb evaporated from melt but no ⁶⁹ Zn transport observed. Ingot still oxidised. 69% of residual removed by etching off oxide layer.
2(1)	3.6	10	Impure argon	Nil	Etching did not reduce activity. Set up for vacuum bake after removing oxide.
2(2)	3.6	75	High vacuum	99.2	Air bled into system before freezing. 70% of residual ⁶⁹ Zn found in oxide layer.
3	2.16	20	Roughing vacuum (0.1 mm Hg)	92.3	No visible oxidation. Activity not reduced by etching.
4	2.35	240	High vacuum	94.3	No visible oxidation. Activity not reduced by etching.
5	35	135	High vacuum	99.7	No visible oxidation. Activity not reduced by etching.
6 (In only)	25	135	High vacuum	99.9+	No visible oxidation. Activity not reduced by etching.

*The apparent donor level in hydrogen-grown n-type InSb increases by 3 to 5×10^{13} carriers/cm³ from the "as-grown" value over a period of four weeks at room temperature. The electron mobility also shows a marked increase over the same period of time.

material by prolonging the pre-evaporation stage, but no appreciable difference was found using periods up to 11 h. In order to study the volatilisation of Zn in more detail, an experiment was then carried out in which ^{69}Zn tracer was added to small ingots of InSb and vacuum baking operations performed. From the results in table III, it can be seen that Zn is effectively removed from the melt under vacuum when present in ppm concentrations. Under oxidising conditions there is a tendency for Zn to migrate to the surface layer, where it may be removed by etching. It was hoped to turn the latter behaviour to advantage by allowing ingots to oxidise at the end of the pre-evaporation period, removing the surface layer by etching and then proceeding to zone refine the Zn-depleted product. Results in terms of final Zn content were disappointing, probably due to contamination arising from the handling and etching involved. A similar effect was found when attempts were made to crop off the Zn-bearing region after a series of zone passes, before repeating the closed system cycle, or when an ingot was subjected to a continuous series of such cycles. Fig. 10 shows the results obtained from the latter experiment; specimens for measurement being extracted after each individual cycle. All the results are plotted

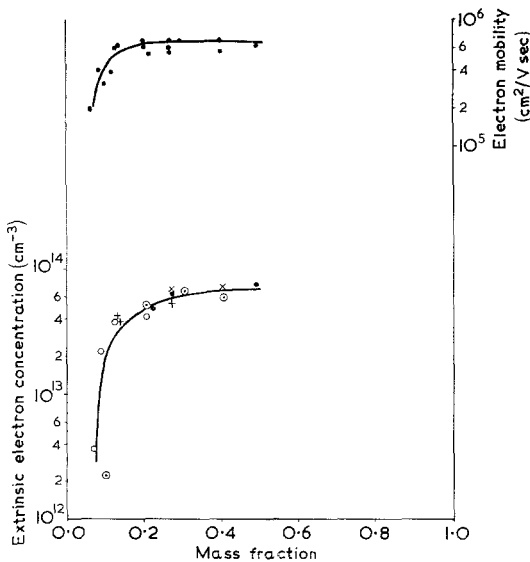

Figure 10 Distribution of carrier concentration and mobility values in an ingot after 5 closed-system cycles. Specimens were cut from the ingot after each evaporation and single crystal zone-refining cycle. Different markings are used for the carrier values which were determined after each cycle. The results indicate a remarkable reproducibility in the procedure.

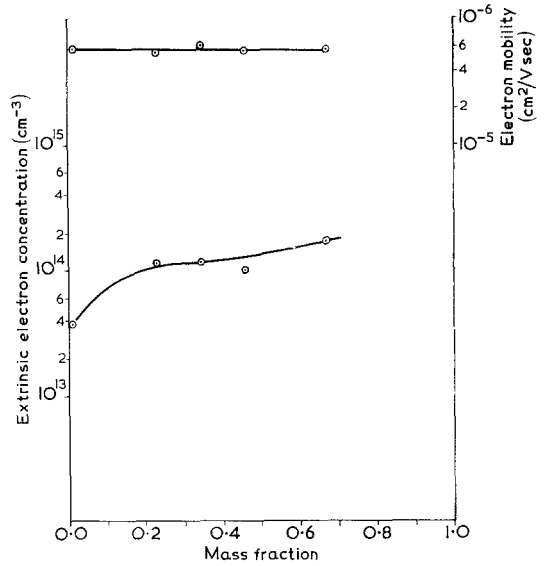

Figure 11 Distribution of carrier and mobility values in a single crystal ingot in which the final zone pass was carried out in vacuum.

and remarkably little scatter has resulted, indicating that no marked change in distribution was involved at any stage.

A method of producing a completely n-type single crystal was eventually developed. This involved a final zone pass in vacuo, taking care to avoid deposition of condensate from the molten zone on to the ingot surface. Electrical properties of an ingot processed in this manner are given in fig. 11, and it can be seen that no substantial rise in the general level of mobility has resulted, although elimination of the p-type region increases the high mobility range.

4.4. Many-Pass Zone Refining

The assumption was made when this work was undertaken, that if efficient segregation of solutes resulted from zone refining of suitably-oriented single crystals, it would be unnecessary to use large numbers of zone passes. This was based on the observation that the interface distribution coefficient, k^* , for Te in single crystal InSb oriented off (111), is 0.5 [14]. Zone refining theory predicts that the Te level in the portion of the ingot adjacent to the seed should be reduced by a factor of $\sim 2^{10}$ after 10 zone passes under the stated conditions. For this reason, evaluation of the electrical properties of our zone-refined single crystals was normally carried out after 10 to 15 passes. Since the initial n-type level in the pre-evap-

orated starting material was uniformly 1×10^{14} carriers/cm³, it is not possible to account for the observed value of the n-type level of approximately 3×10^{13} carriers/cm³ in the zone-refined single crystals in terms of Te. This was the lowest "residual donor" content found, and the mobility was high enough to suggest the absence of serious acceptor compensation.

In view of the somewhat better results quoted by Vinogradova [1], it was decided to perform some experiments using larger numbers of zone-refining passes, having in mind the possibility that some hitherto unsuspected, slowly segregating impurity might be involved. A common stock of pre-evaporated source material was used throughout.

Results of these experiments are given in table IV and lead to the following conclusions:

- (a) Passing zones through an unseeded InSb ingot does not normally result in a single crystal end product.
- (b) Segregation of the "residual donor" proceeds slowly in the case of polycrystal zone refining. This is still consistent with the view that Te is the species involved.
- (c) For suitably-oriented single crystals, large numbers of zone passes do not lead to an improvement in the value of the "residual donor" level or the electron mobility.

5. Discussion

The procedure for zone refining outlined above, i.e. as a single crystal after an evaporation stage in the same apparatus gives rise to the following advantages:

- (a) Volatile acceptor impurities are reduced to a low level before zone refining is commenced, thus avoiding the necessity to pass a large number of zones in order to remove Zn from the bulk of the ingot.
- (b) Provided the orientation is selected to avoid non-uniform distributions due to the "facet effect", Te can be efficiently segregated by zone refining. Assuming an initial Te concentration of 1 to 2×10^{14} atoms/cm³ (which is reasonable for good quality starting material), the residual donor level can be brought to below 5×10^{13} atoms/cm³ over a substantial portion of the ingot after only 5 zone passes. Further zone passes increase the yield of material of this quality but

uncompensated values of the "residual donor" level much below 3×10^{13} atoms/cm³ have not been observed to result from this treatment.

- (c) The end product is a single crystal with uniform radial carrier distribution and low dislocation density. It is not necessary to use a final Czochralski pulling stage. The crystal growing technique can also be used to produce doped ingots by zone levelling. This gives a yield advantage over the Czochralski method when rapidly segregating dopants are used.

While it is felt that the changes in carrier distribution brought about by pre-evaporation and single crystal zone refining can be explained for the most part in terms of transportation of Zn and Te, there appears to be no obvious explanation for the observed limitation of the "residual donor" level at a value of about 3×10^{13} atoms/cm³ and a mobility at 7.5×10^5 cm²/V sec, even though marginally better values are quoted by Vinogradova *et al* [1] and by Parker *et al* [2]. The reduction of the "residual donor" level, which occurs in parallel with the maintenance of a reasonably high mobility, indicates that a real diminution in the number of donors (N_D) is brought about by zone refining, but, as stated above, a comparatively small number of zone passes would give an even lower figure for the donor level if only Te were involved. One must conclude that some additional source of donor centres is the limiting factor.

When the "closed system" cycle is completed by passing a zone in vacuo, an ingot can be obtained which is completely n-type at 77° K. There are good grounds for considering that this signifies almost complete removal of the acceptor which has $k > 1$. The resulting carrier profile shown in fig. 11 is in striking contrast to those quoted by Vinogradova [1] and by Parker [2], where very high initial acceptor concentrations were in evidence. It should be noted, however, that although we have apparently succeeded in removing this important source of acceptor centres, the general level of mobility has not thereby been increased. If mobility values in excess of 1×10^6 cm²/V sec are realisable, as claimed by other workers, it is not clear why such figures were not attained in the present work. The variation in mobility with dislocation density reported by Parker [2] was not observed at the levels obtaining in our

TABLE IV Experiments involving large number of zone passes

Assembly conditions	Ambient	No. of zone passes	Zone length (cm)	Traverse speed	Seed end extrinsic carriers/cm ³	Minimum extrinsic carriers/cm ³	Corresponding mobility cm ² /V sec	Final structure
30 cm ingot sealed in quartz ampoule. No seed	0.7 atm argon	8	5	1.0 cm/h	1.5×10^{15} (acceptors)	8×10^{13} (donors)	2.5×10^6	Polycrystal
		30	2					
30 cm ingot in smooth quartz boat. No seed	0.7 atm argon	6	5	0.75 cm/h	3×10^{14} (acceptors)	2×10^{14} (donors)	3.0×10^6	Polycrystal
		24	2					
		13	0.5					
32 cm ingot in smooth quartz boat. No seed	1.1 atm argon	53	2.5	3.0 cm/h	non-uniform (p- and n-type)	1×10^{14} (donors)	2.8×10^6	Polycrystal
31 cm ingot in smooth quartz boat. No seed	30 hydrogen 29 argon 1.1 atm	2	5	6 cm/h	non-uniform (p-type)	1.15×10^{14} (donors)	3.0×10^6	Mainly [111] single crystal. Very high dislocation density
		57	2.0	0.75 cm/h				
32 cm ingot in silica-coated boat. [221] seed	1.1 atm argon	26	2.5	3.0 cm/h	non-uniform (p-type)	2.64×10^{13} (donors)	5.0×10^6	Isolated growth twins. Dislocation-free

material, no apparent trend being produced from ingot to ingot with densities varying between zero and 10^4 sites/cm². It is known [21] that mobility will suffer degradation in very highly strained material.

Material having a "residual donor" level and mobility similar to that produced by single crystal zone refining can also be obtained (albeit in low yield) from Czochralski crystals grown from pre-evaporated and zone-refined polycrystalline material [3]. Also, by courtesy of several other workers in this field, we have been able to measure samples of purified InSb originating in laboratories sited in the USA, USSR, Canada, France and West Germany, in addition to samples from various organisations in the UK. Electrical characteristics on these samples were found to be generally similar to those obtained in the present work. It is reasonable to assume that these samples are representative of a variety of source elements, and this suggests that, if the limitation on characteristics is imposed by an impurity, then such impurity is a very common one.

Attempts on our part to determine if any of the materials used in processing impose a limitation on purity have been unsuccessful. The same end product is found using boats entirely composed of SiO₂ (colloidal silica on abraded quartz) and entirely composed of carbon (abraded vitreous carbon). A similar constant level is produced when zone refining is carried out in hydrogen, helium, argon, and vacuum ambients.

The possible sources of the residual donor, if it is a chemical defect, therefore appear to be limited to the following:

- (a) An element with $k \approx 1$, irrespective of orientation. No such impurity is known at the present time. The constancy of the residual donor level found in InSb originating from different starting materials does not support this hypothesis.
- (b) Ubiquitous impurities with limited solubility in InSb, e.g. oxygen. The evidence from different boats and ambients conflicts with this view.
- (c) Fast-diffusing impurities.

Although it cannot be stated unequivocally that a chemical impurity is not involved, it appears at least as likely than an explanation of the observed limitation may eventually be forthcoming from considerations of structure. In this context, it is improbable that dislocations

are involved at low or average levels of population, and effects due to vacancies may be a more rewarding area for further study.

Acknowledgements

We gratefully acknowledge valuable discussions with our colleagues and other workers in this field, also we appreciate the careful work of Mr W. H. E. Wilgoss, Miss V. M. Doyle, Mr J. C. Weaver, Mr J. Hyndes and Mr C. R. Norfolk.

Crown Copyright - reproduced with the permission of the Controller, HM Stationery Office.

References

1. K. I. VINOGRADOVA, V. V. GALAVANOV, D. N. NASLEDOV and L. I. SOLOV'eva, *Soviet Phys. Solid State* **1** (1959) 364.
2. S. G. PARKER, O. W. WILSON and B. H. BARBEE, *J. Electrochem. Soc.* **112** (1965) 80.
3. K. F. HULME and J. B. MULLIN, *Solid State Electronics* **5** (1962) 211.
4. T. C. HARMAN, *J. Electrochem. Soc.* **103** (1956) 128.
5. S. C. LIANG, "Compound Semiconductors", Vol. 1—Preparation of III-V Compounds (Reinhold, 1962), p. 227.
6. K. F. HULME and J. B. MULLIN, *J. Electron. Control* **3** (1957) 160.
7. R. E. J. KING and B. E. BARTLETT, *Philips Tech. Rev.* **22** (1961) 217.
8. R. C. BOURKE, S. E. MILLER and W. P. ALLRED, *J. Electrochem. Soc.* **106** (1959) 61c.
9. J. A. M. DIKHOPF, *Solid State Electronics* **1** (1960) 202.
10. A. R. MURRAY and D. A. DAVIES, unpublished report (AEI).
11. A. TRAINOR and B. E. BARTLETT, *Solid State Electronics* **2** (1961) 106.
12. P. J. HOLMES, *J. Phys. Chem. Sol.* **24** (1963) 1239.
13. P. HAASEN, *Trans. Met. Soc. AIME* **209** (1957) 30.
14. J. B. MULLIN, "Compound Semiconductors", Vol. 1—Preparation of III-V Compounds (Reinhold, 1962), p. 365.
15. R. K. MUELLER and R. L. JACOBSON, *J. Appl. Phys.* **32** (1961) 550; 1406.
16. I. G. CRESSEL and J. A. POWELL, "Progress in Semiconductors", Vol. 2 (Heywood, London, 1957), p. 139.
17. W. C. DASH, *J. Appl. Phys.* **30** (1959) 459.
18. R. R. HABERECHT, "Compound Semiconductors", Vol. 1—Preparation of III-V Compounds (Reinhold, 1962), p. 92.
19. P. J. W. NOBLE, unpublished results (Texas Instruments Ltd).
20. J. B. MULLIN, to be published.
21. A. F. W. WILLOUGHBY, thesis, University of London (1965).